



# CLASS 150 CAST STEEL BALL VALVE

**FIG.# 4E-41WCB16T**

**Sizes: 2"-8" @ ANSI 150**

Carbon Steel Body, 316 Stainless Steel Ball  
 2-PCS, Floating Ball, Full Port  
 Fire Safe Design and Anti-Static\*  
 Design and Manufacture: API 6D  
 Face to Face Dimensions: ASME B16.10  
 Flange Ends Dimensions: ASME B16.5  
 Fire Safe Test: API 607  
 Pressure Test: API 598

CLASS	Pressure Test (MPa)		
	Shell Test	Seat Test	Air Test
150 LB	3.0	2.2	0.6
Applicable Temperature		- 29°C (- 20°F) ~ 120°C (248°F)	
Applicable Media		W.O.G.	

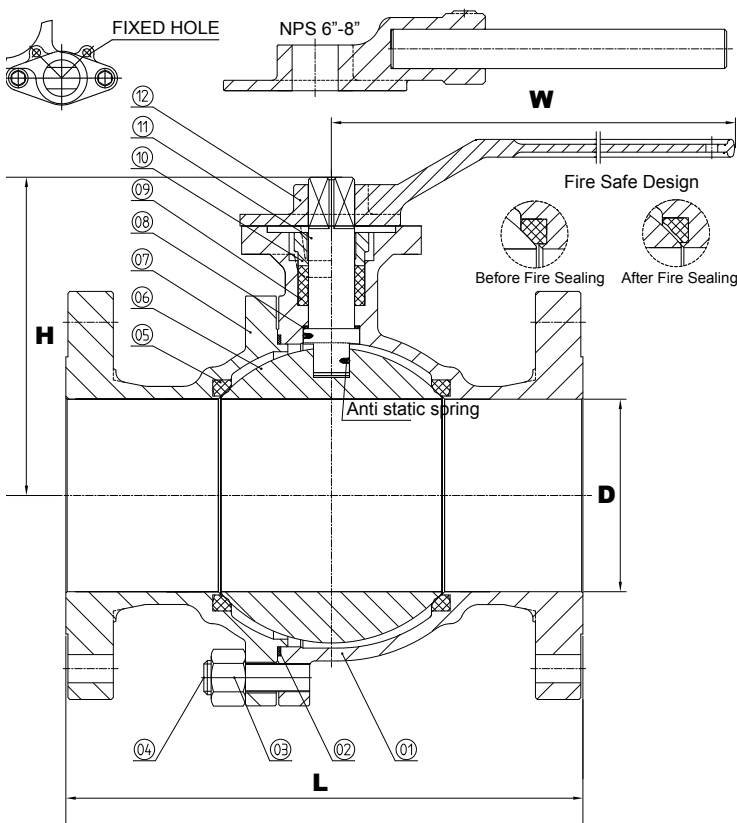

## MATERIAL LIST

No.	Part Name	Material
1.	Body	A-216 WCB
2.	Body Gasket *	SS 304 + Graphite / PTFE*
3.	Nut	A194 - 2H
4.	Stud	A193 - B7
5.	Seat *	PTFE / RPTFE*
6.	Ball	A182 - F316
7.	Bonnet	A216 - WCB
8.	Thrust Washer	PTFE
9.	Packing *	PTFE / Graphite / RPTFE
10.	Gland	A216 - WCB
11.	Stem	SS 316
12.	Lever	A216 - WCB

## DIMENSIONS & WEIGHT

SIZE	unit	2"	2-2/1"	3"	4"	6"	8"
D	inch	2.01	2.52	2.99	4.02	5.98	7.99
	mm	51	64	76	102	152	203
L	inch	7.00	7.50	8.00	9.00	15.50	18.00
	mm	178	190	203	229	394	457
H	inch	5.51	6.50	7.01	9.06	12.20	13.78
	mm	140	165	178	230	310	350
W	inch	9.84	11.81	13.78	19.69	31.50	39.37
	mm	250	300	350	500	800	1000
Weight	lbs.	26.5	39.7	52.9	83.8	180.8	319.7
	kgs.	12	18	24	38	82	145
Torque	N·m	30	60	80	130	250	470

- NOTE:**
- 316 SS Trim and Others available upon request
  - Handwheel, lever and Gear Operator must be specified at the point of order.
  - Please specify the material of Body Gasket, Seat and Packing when placing your order, otherwise 4E will ship out products in accordance with our inventory.
  - Specifications subject to change without notice.

# CLASS 300 CAST STEEL BALL VALVE

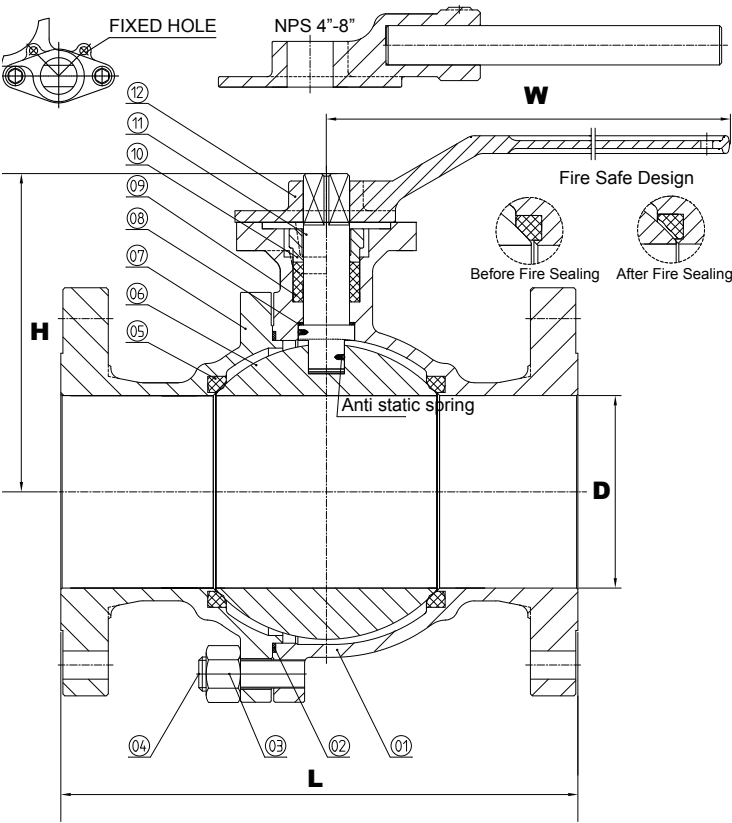

**FIG.# 4E-43WCB16T**

**Sizes: 2"-8" @ ANSI 300**

Carbon Steel Body, 316 Stainless Steel Ball  
 2-PCS, Floating Ball, Full Port  
 Fire Safe Design and Anti-Static\*  
 Design and Manufacture: API 6D  
 Face to Face Dimensions: ASME B16.10  
 Flange Ends Dimensions: ASME B16.5  
 Fire Safe Test: API 607  
 Pressure Test: API 598

CLASS	Pressure Test (MPa)		
	Shell Test	Seat Test	Air Test
300 LB	7.5	5.5	0.6
Applicable Temperature	- 29°C (- 20°F) ~ 120°C (248°F)		
Applicable Media	W.O.G.		



## MATERIAL LIST

No.	Part Name	Material
1.	Body	A-216 WCB
2.	Body Gasket	SS 304 + Graphite
3.	Nut	A194 - 2H
4.	Stud	A193 - B7
5.	Seat	RPTFE
6.	Ball	A182 - F316
7.	Bonnet	A216 - WCB
8.	Thrust Washer	PTFE
9.	Packing	Graphite
10.	Gland	A216 - WCB
11.	Stem	SS 316
12.	Lever	A216 - WCB

## DIMENSIONS & WEIGHT

SIZE	unit	2"	3"	4"	6"	8"
D	inch	2.01	2.99	4.02	5.98	7.99
	mm	51	76	102	152	203
L	inch	8.50	11.12	12.00	15.88	19.75
	mm	216	283	306	403	502
H	inch	5.59	7.01	9.06	12.20	13.78
	mm	142	178	230	310	350
W	inch	9.84	13.78	19.69	31.50	39.37
	mm	250	350	500	800	1000
Weight	lbs.	35.3	75.0	123.5	275.6	489.4
	kgs.	16	34	56	125	222
Torque	N-m	60	140	260	930	1550

**NOTE:** 1. 316 SS Trim and Others available upon request  
 2. Handwheel, lever and Gear Operator must be specified at the point of order.  
 3. Specifications subject to change without notice.